

Starter Motor — 5.4L (4V)

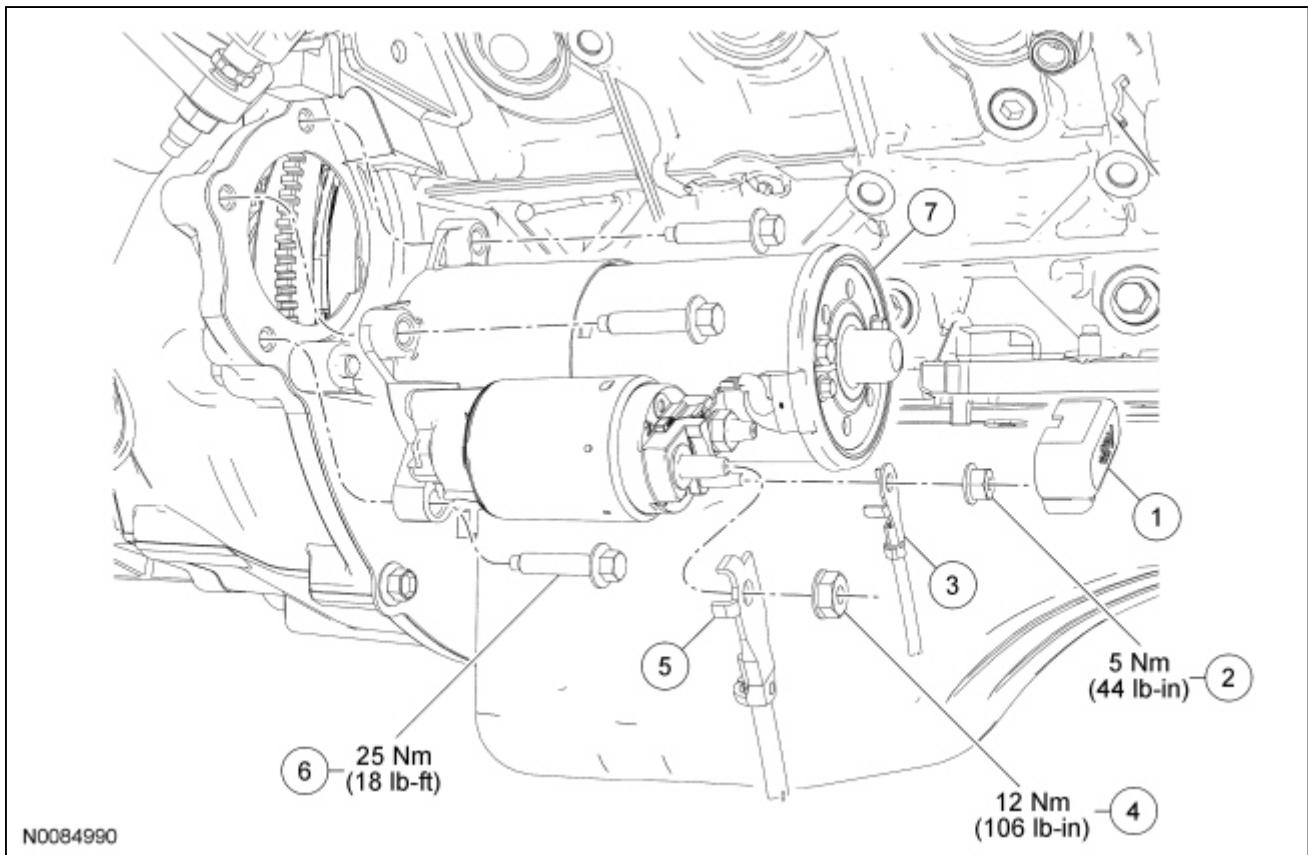

Item	Part Number	Description
1	11N087	Starter solenoid terminal cover
2	W705790	Starter solenoid S-terminal nut
3	14463	Starter solenoid S-terminal eyelet
4	N805403	Starter solenoid B+ terminal nut
5	14463	Starter solenoid B+ terminal eyelet
6	W500310	Starter motor mounting bolt (3 required)
7	11000	Starter motor

Removal

⚠ WARNING: Always disconnect the battery ground cable at the battery before disconnecting the starter motor battery terminal lead. If a tool is shorted at the starter motor battery terminal, the tool can quickly heat enough to cause a skin burn. Failure to follow this instruction may result in serious personal injury.

1. With the vehicle in NEUTRAL, position it on a hoist. For additional information, refer to [Section 100-02](#).
2. Disconnect the battery ground cable. For additional information, refer to [Section 414-01](#).
3. Remove the starter solenoid terminal cover.
4. Remove the 2 starter solenoid terminal nuts and position aside the wires.

5. Remove the 3 bolts and the starter motor.

Installation

1. **NOTE:** To make sure of correct starter installation, the upper bolt must be tightened first.

NOTE: Clean the starter motor mounting flange and mating surface of the starter motor to make sure there is a correct ground connection.

Position the starter motor and install the 3 bolts finger-tight.

- Tighten the upper bolt to 25 Nm (18 lb-ft).
 - Tighten the 2 lower bolts to 25 Nm (18 lb-ft).
2. Install the wires and the 2 starter solenoid terminal nuts.
 - Tighten the starter solenoid B+ terminal nut to 12 Nm (106 lb-in).
 - Tighten the starter solenoid S-terminal nut to 5 Nm (44 lb-in).
 3. Install the starter solenoid terminal cover.
 4. Connect the battery ground cable. For additional information, refer to [Section 414-01](#).
-